

90° Transfer Roller Conveyor

02

- Fast and precise 90° product transfer
- Continuous flow with powered rollers
- Robust and reliable structure for intensive use
- Easy system integration

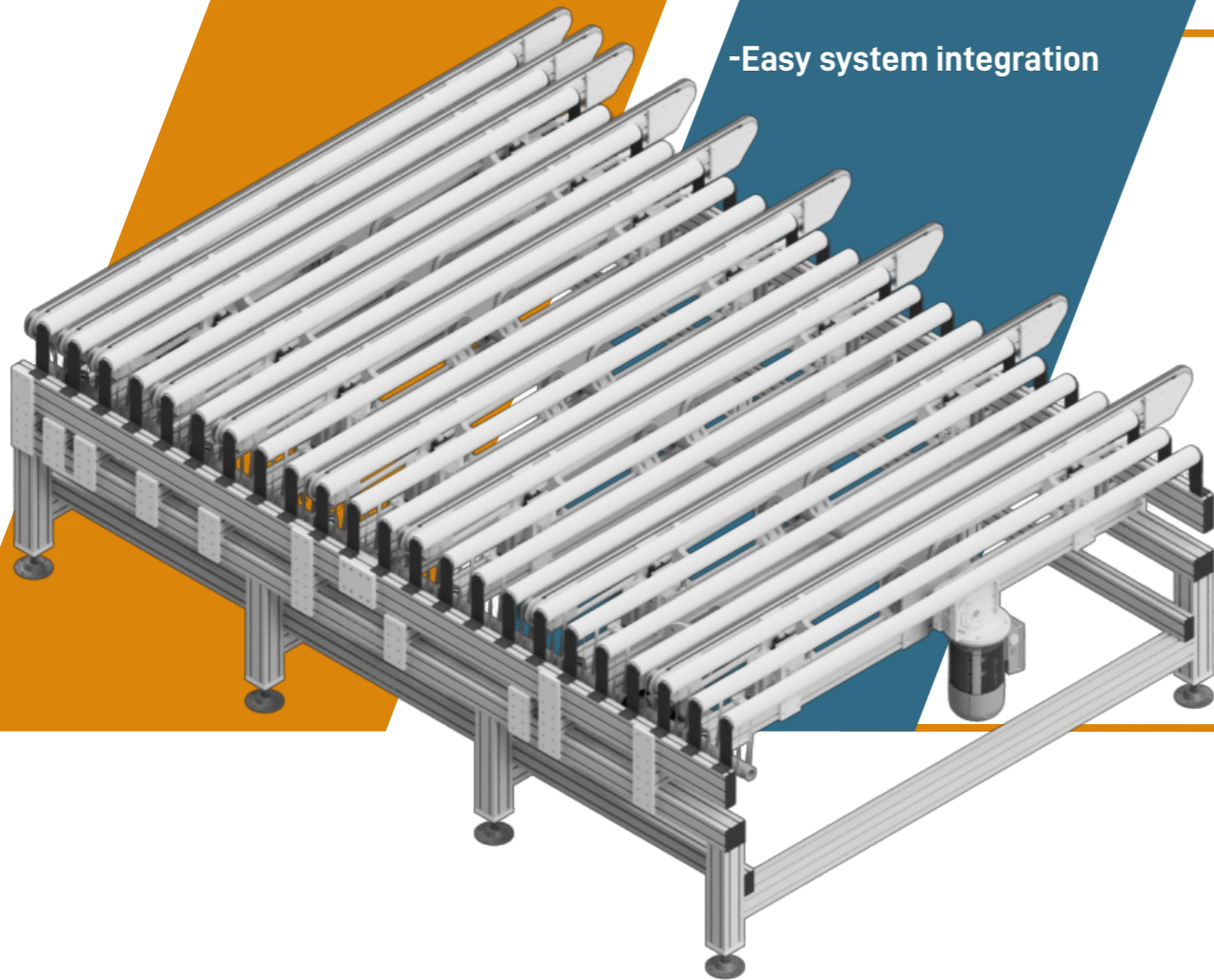

Powered Roller Conveyor with Integrated Cross Turner

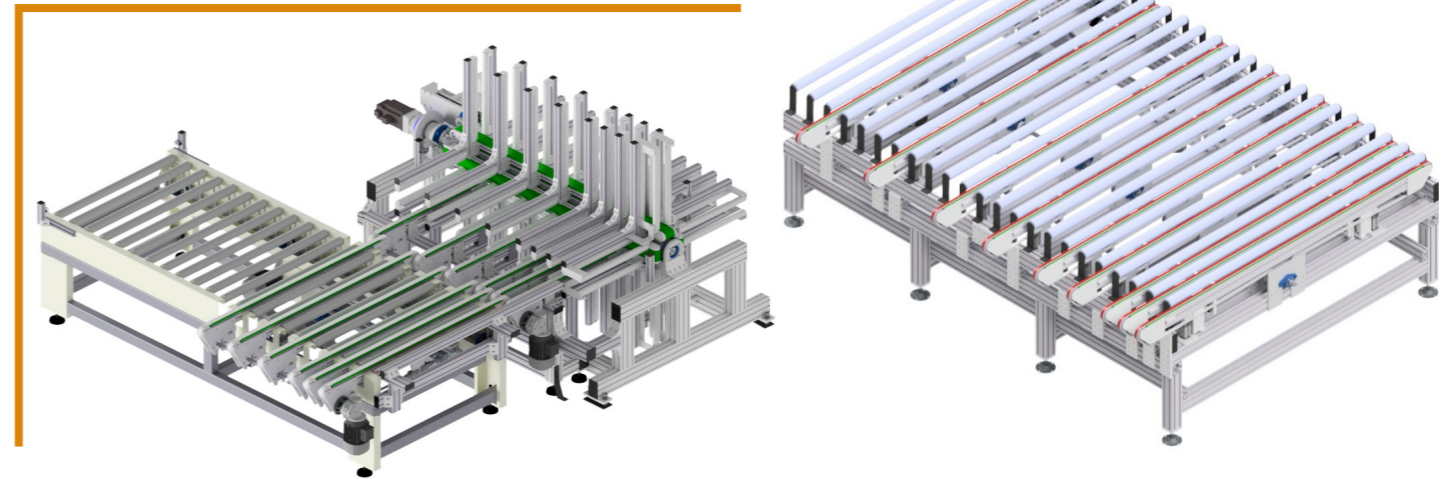

Description

The 90° Transfer Roller Conveyor is an automated handling system designed to divert packages or pallets from a main conveyor line to a secondary line with maximum precision. The powered roller conveyor ensures continuous and controlled product flow, while the 90° transfer unit — equipped with liftable belts or rollers — enables fast and reliable direction changes. This system is ideal for logistics installations, packaging lines, and high-efficiency production environments.