

Pallet Conveyor System

05

- Automated and safe pallet handling
- Reduced operating times and manual intervention
- Heavy-duty structure for high loads
- Easy integration into production lines

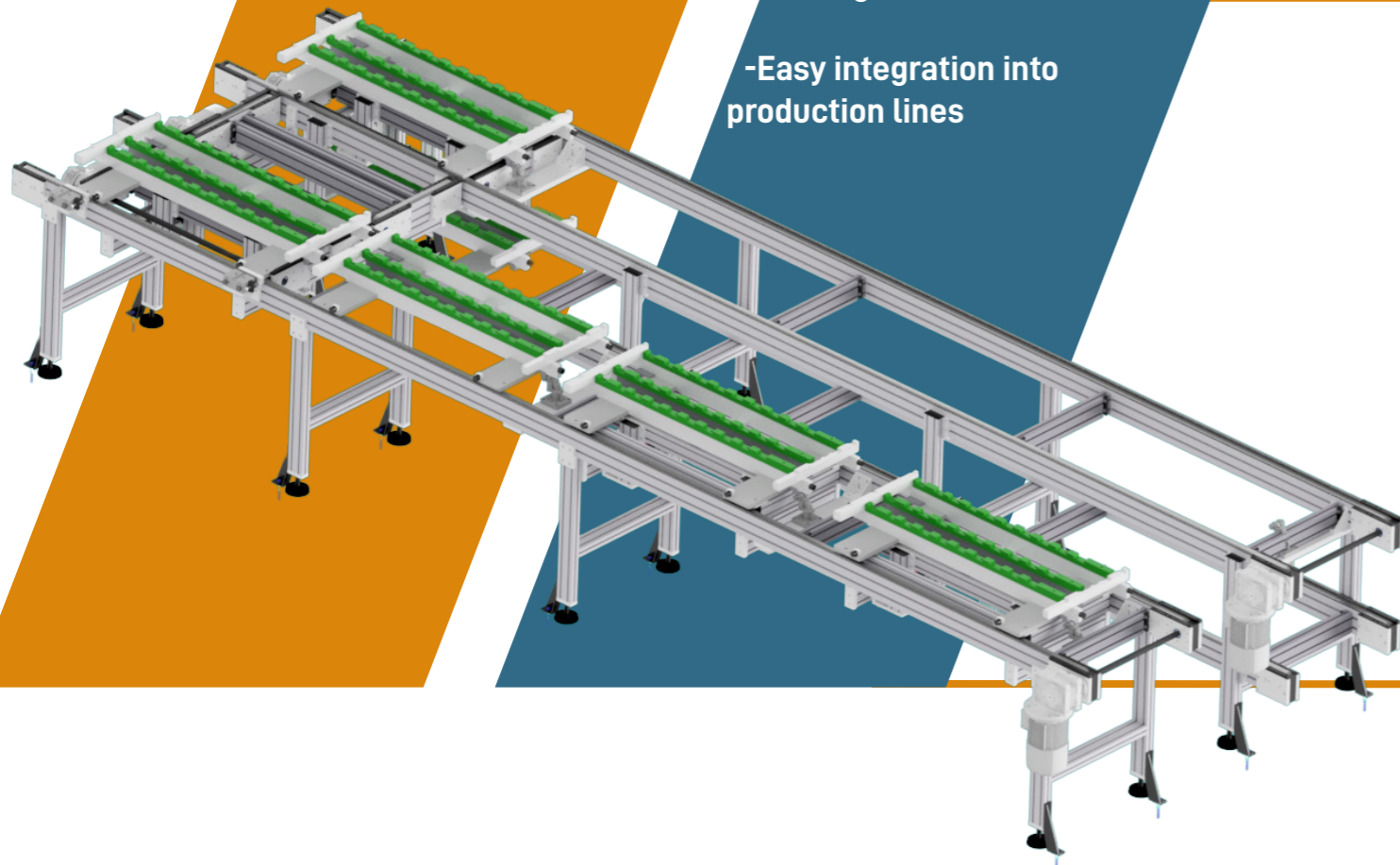

Sollevatore verticale

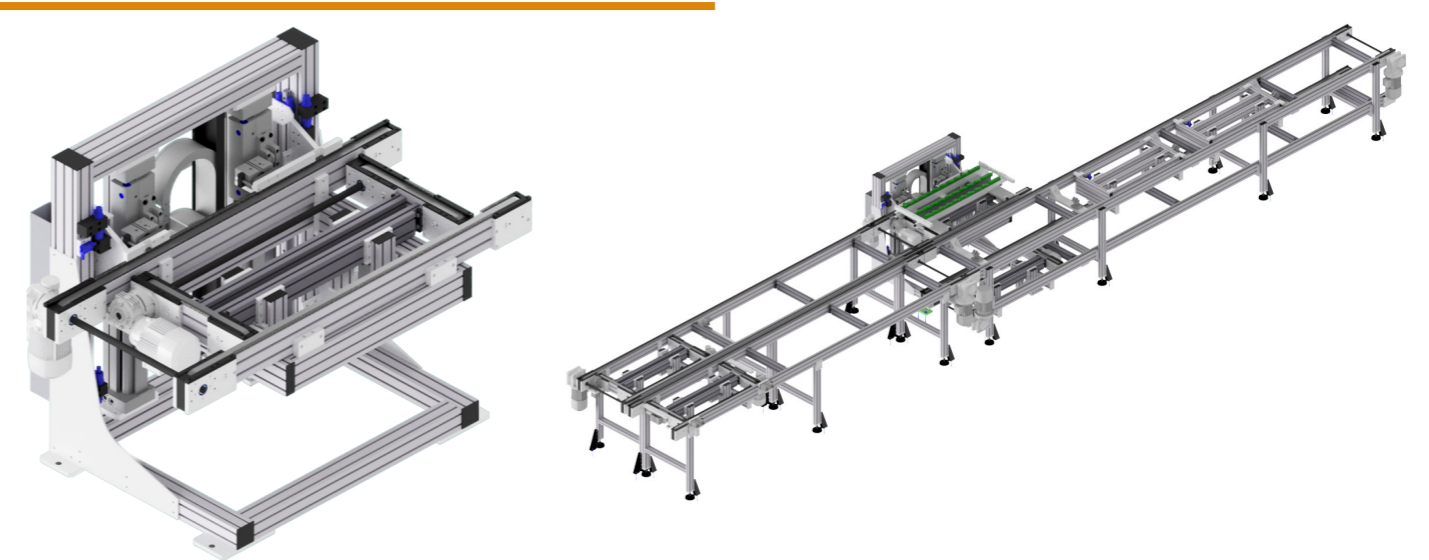

Description

Pallet Conveyor Systems provide modular and flexible solutions for handling pallets within production lines, warehouses, and logistics installations. Modules can be configured in linear, curved, or complex layouts and integrated with workstations, rotating tables, vertical lifts, and robotic systems.

Thanks to integrated control systems and controlled accumulation capabilities, the system ensures precision, continuous flow, and compatibility with industrial automation solutions, allowing efficient management of medium and heavy loads.

