

AS/RS Stacker Crane

07

- Vertical and aisle movement
- Maximum space utilization and high storage capacity
- High precision and operational reliability
- Increased productivity and operational safety

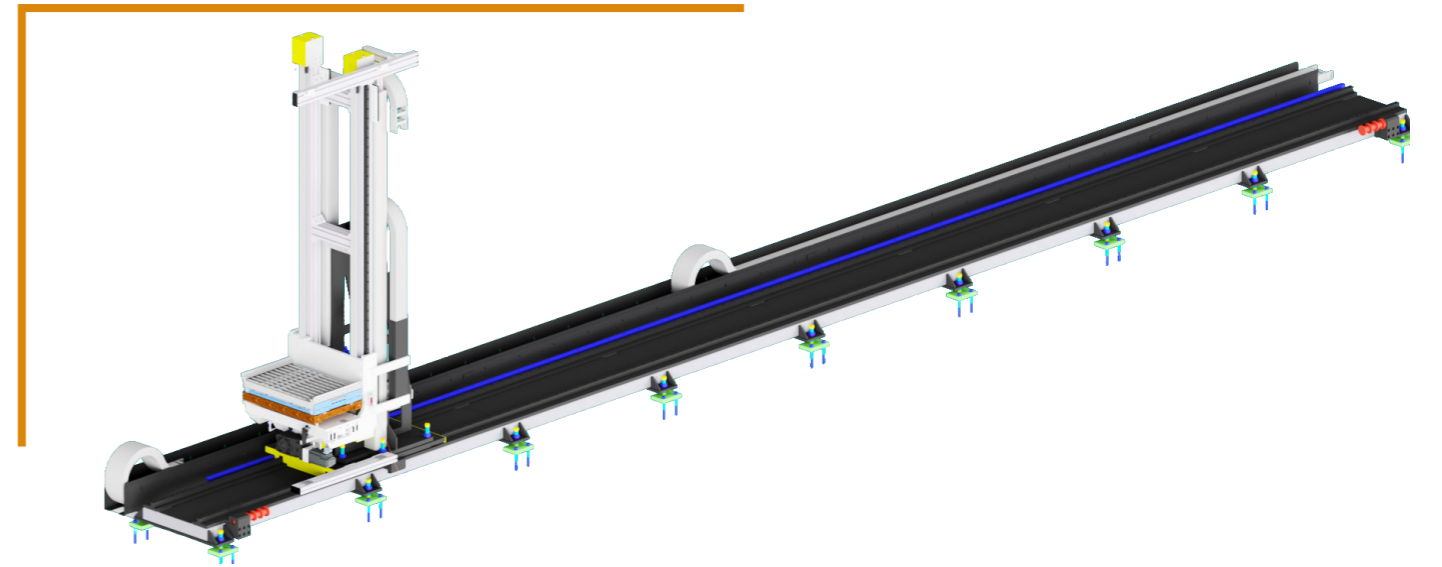
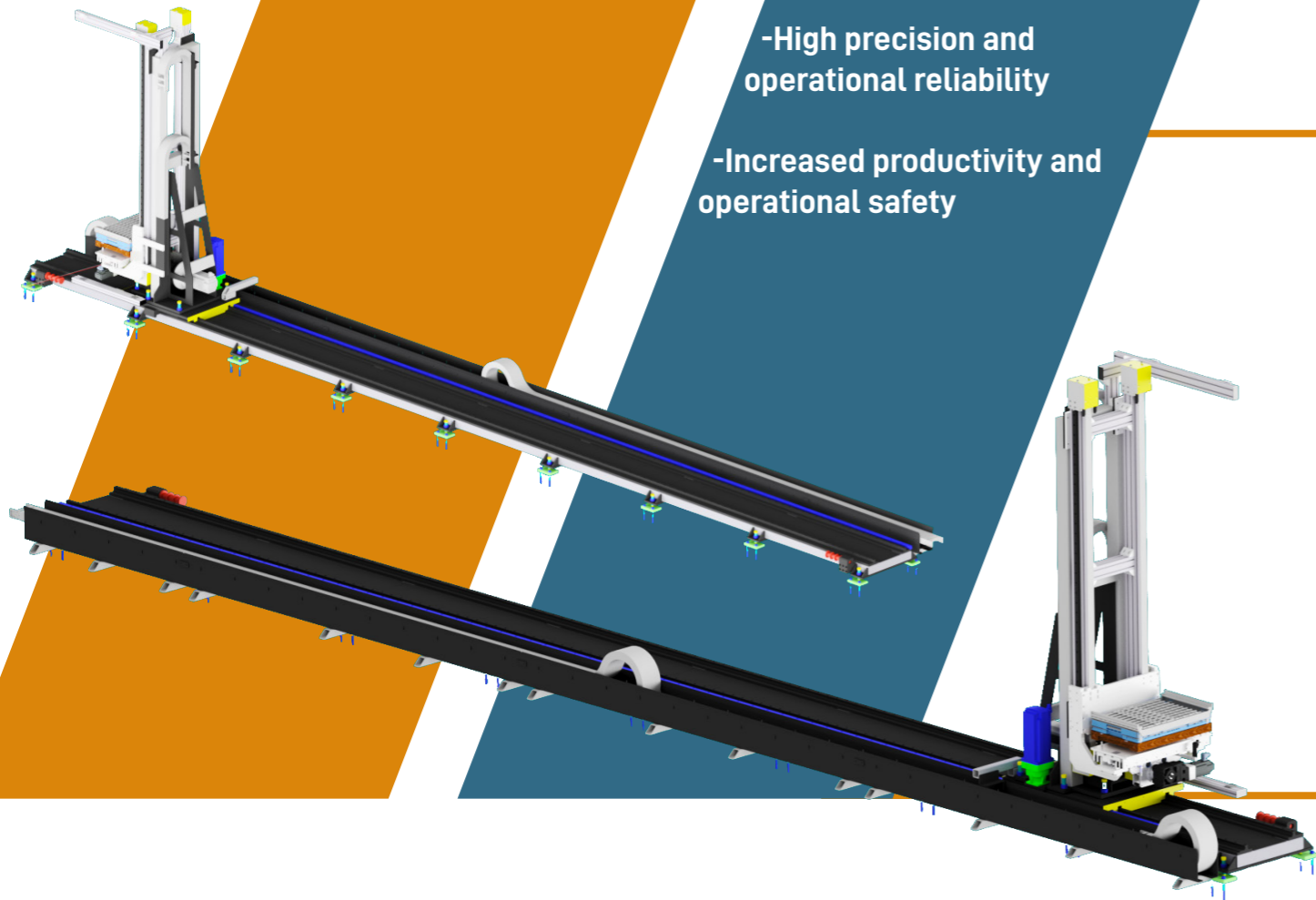

Description

AS/RS Stacker Cranes are high-efficiency automated storage and retrieval systems designed to handle pallets in high-bay automated warehouses. Operating along dedicated aisles, they perform storage and retrieval operations quickly and precisely using telescopic forks and advanced electronic control systems. These systems ensure operational continuity, optimized warehouse space utilization, and reduced handling errors, making them ideal for logistics, distribution, and high-intensity production environments.